

PhotoDECT

Amplified Digital Cordless Telephone With Large Buttons



CONTENTS

CONTENTS	1
INTRODUCTION	4
Unpacking the Telephone	5
DESCRIPTION	6
General Description	6
INSTALLATION	14
Location	14
Setting Up	15
Battery Use	16
On/Off Settings	17
HANDSET SETTINGS	18
Alarm Setting	18
Audio Setup	19
Ringer Setup	20
Tone Setup	22
Range Alarm	23
Language Setting	24
HS Label	25
Auto Answer	26
LCD Settings	27
Date & Time Setting	28
Select Base	31
Handset Default	32
BASE SETTINGS	33
Terminate Handset	33
Dial Mode Setting	34

CONTENTS

Flash Time Setting	35
Modify PIN	36
Base Default	37
USING THE TELEPHONE	38
Making a Call	38
Receiving a Call	39
Hands Free	39
Mute Function	40
Receiving Volume	40
Last Number Redial	41
Recalling Recent Numbers	41
Adding Recent Numbers to the Phone Book	42
Deleting Recent Numbers	44
Flash Signal	46
Paging the Handset	46
Call Timer	46
Key Lock	46
CALLER ID	47
View Caller ID Book	48
Dial a Number from the Caller ID Book	48
Add a Number from the Caller ID Book to the Phone Book	49
Delete a Number from the Caller ID Book	50
Delete all Numbers from the Caller ID Book	50
PHONE BOOK	51
Create a Phone Book Entry	51
View Phone Book Entries	53

CONTENTS

Dialling using a Phone Book Entry	53
Modify a Phone Book Entry	54
Delete a Phone Book Entry	55
Delete all Phone Book Entries	56
Phone Book Status	57
PHOTO DIAL	58
Storing a Number to Photo Dial Memory	58
Dialling a Photo Dial Number	58
Delete and Replace a Photo Dial Number	58
Delete all Photo Dial Numbers	58
ADDITIONAL HANDSETS & BASES	59
Register a New Handset	60
Select a Base	61
Release a Handset	61
Internal Calls	62
Call Transfer between Handsets	63
Three Way Conference Call	64
CALL WAITING	65
Caller ID on Call Waiting	65
TROUBLESHOOTING	66
SAFETY INFORMATION	68
GUARANTEE	69
RECYCLING DIRECTIVES	71

INTRODUCTION

Congratulations on purchasing your Geemarc PhotoDECT telephone. This telephone offers all the advantages of cordless technology (compliant with Digitally Enhanced Cordless Telecommunications-DECT standard) together with an easy to see big button keypad, ideal for those who suffer with poor sight.

There are photo dial buttons, also designed to make dialling easier because you will be able to identify these photo dial buttons with pictures of your friends and family.

This telephone is hearing aid compatible.

Its is important that you read the instructions below in order to use your Geemarc telephone to its full potential. Keep this user guide in a safe place for future reference.

This guide explains how to use the following telephone:

PhotoDECT

This guide applies to single and multiple handset systems.

DESCRIPTION

Unpacking the Telephone

When unpacking the telephone, you should find the following in the box:

- 1 PhotoDECT handset
- 1 PhotoDECT base
- 1 Mains power adaptor
- 1 Telephone line cord
- 2 x AAA Ni-MH rechargeable batteries
- 1 User Guide



For product support and help visit our website at

www.geemarc.com

Telephone 01707 384438

Or fax 01707 832529

DESCRIPTION

General Description

Handset Description (front)

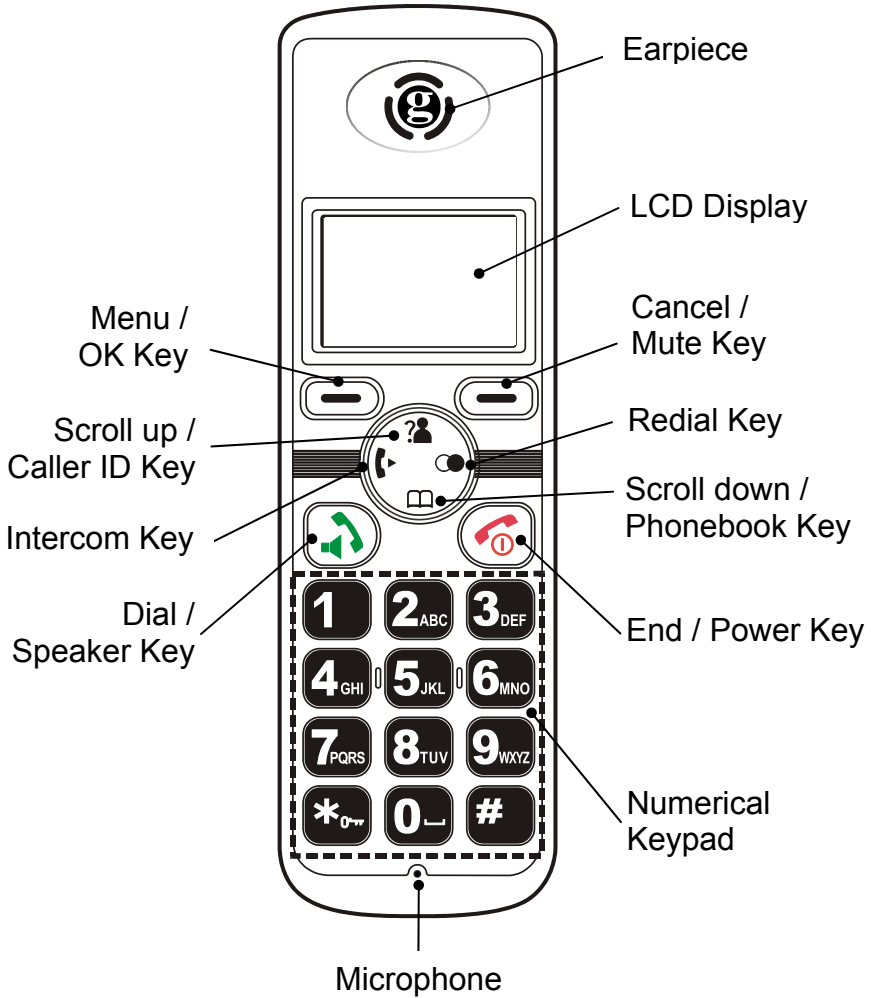

DESCRIPTION

Handset Description (Rear)

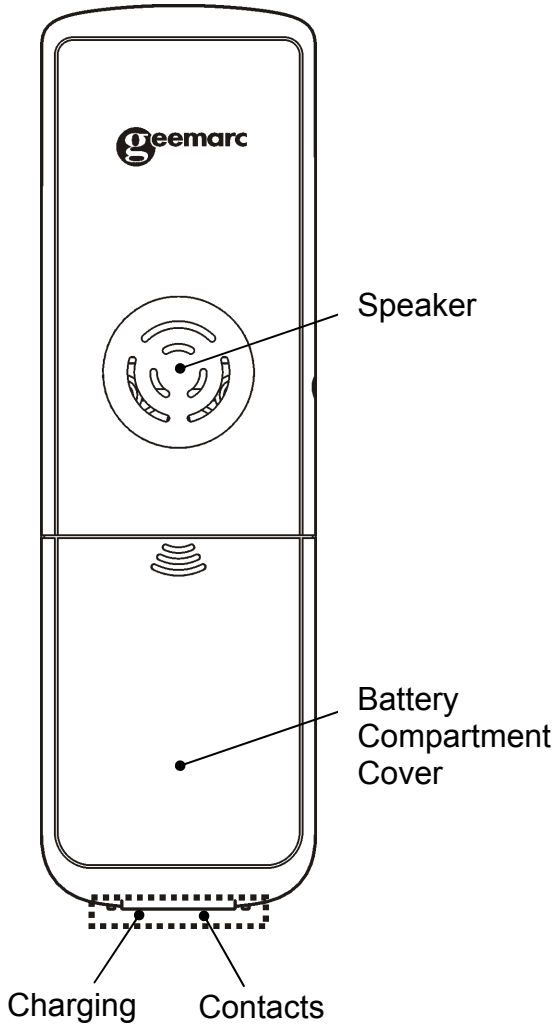

DESCRIPTION



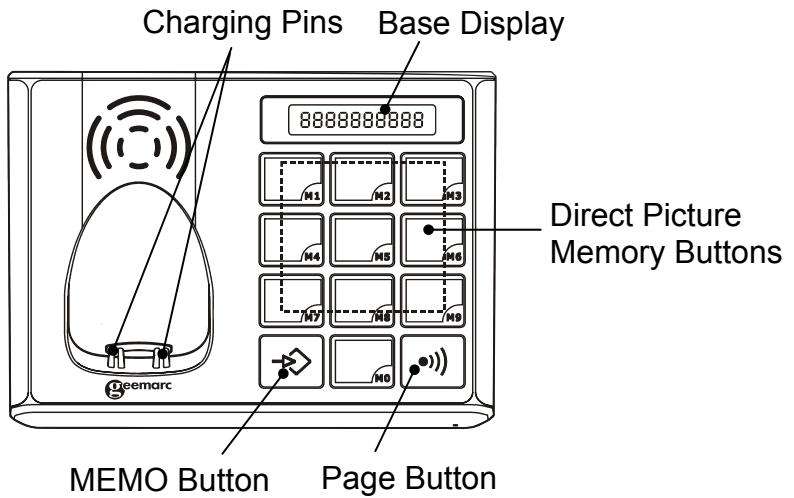

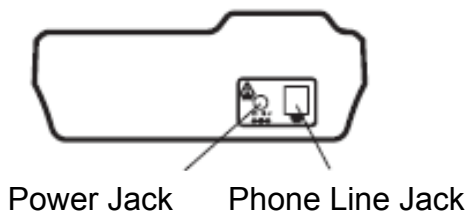

Base Description (Top)





Base Description (Rear)



DESCRIPTION

	<p>Dial/Speaker key</p> <p>Make/Answer a call Activates the speakerphone if pressed during a call</p>
	<p>End/Power key</p> <p>End a call. Long press to power the telephone on and off</p>
	<p>Navigation Button</p> <p> Up/CID key</p> <p>Scroll up through lists and menu options. Increase the earpiece/speakerphone volume during a call. Enter the Caller ID book</p> <p> Down/Phonebook key</p> <p>Scroll down through lists and menu options. Decrease the earpiece/speakerphone volume during a call. Enter the Phonebook</p> <p> Left/INT key</p> <p>Set up an internal call to another handset. Transfer an incoming call to another handset. Set up a conference call with an external line and an internal handset.</p> <p> Right/Redial key</p> <p>Enter the redial book Insert a pause when pre-dialing a number.</p>

DESCRIPTION

	<p>Menu key (left)</p> <p>Enter the menu functions in standby mode. Confirm selections & actions. Performs "Flash" function..</p>
	<p>Menu key (right)</p> <p>Return to the previous menu. Activate mute during a call. Delete an incorrect character/digit</p>
	<p>Star key</p> <p>Press and hold to turn on/off keypad lock function. Set up a conference call.</p>

DESCRIPTION

LCD Screen Description

The LCD screen is split into two distinct areas:

The icon area. This is found at the top of the screen. This displays the various system icons which help you to use the telephone.

The main area. This is found across the centre of the screen. It displays the following:

- number being dialled
- caller ID information
- phonebook
- menu information
- in standby mode, handset number and current time



Signal Strength icon

This is always displayed when your telephone is switched on. It shows the current signal strength. More bars indicate more signal strength. If the handset is too far from the base, this icon will blink on the LCD.



Line icon

This indicates that the line is engaged i.e. off hook



Hands-free

This indicates that hands-free is activated



New Call icon

This indicates that you have missed one or more calls



Key Lock icon

This indicates the keys are locked

DESCRIPTION





Battery Status icon

This is always displayed when your telephone is switched on. It shows the level of battery charge. More bars indicate more battery charge



Alarm Icon

This indicates that the alarm has been set to ring at a specified time

The  (**left side**) key is used to activate the menu. The  is used to deactivate the menu and return to standby mode from any menu.

The  and  keys are used to scroll through the menu.





: move backward through the menu



: move forward through the menu

The  (**left side**) key is also used to confirm an action or choice on a screen.

The  (**right side**) key is used to cancel an action/entry. If you press  (**right side**) from any menu (except whilst in number input mode), the telephone returns to the previous screen.

If you press and hold  (**right side**) from any menu (except whilst in number input mode), the telephone returns to standby mode.

The telephone will automatically return to standby mode from any menu if no button is pressed for 40 seconds.

DESCRIPTION

Menu Map

Caller ID Book	
Phone Book	
	New
	Edit
	Delete
	Delete All
	PB Status
BS Setting	
	Terminate HS
	Dial Mode
	Flash Time
	Modify PIN
	BS Reset
HS Setting	
	Alarm
	Audio Setup
	Ring Setup
	Tone Setup
	Language
	HS Name
	Auto Answer
	LCD Contrast
	Date & Time
	Select Base
	HS Reset
Registration	

INSTALLATION

Location

Ensure you situate the telephone close enough to the power socket so that the cable will reach safely without stretching. Also, the mains power needs to be easily accessible in case you need to disconnect the power.

Make sure the telephone is at least 1 metre away from other electrical products e.g. TV, radio and monitors so as to avoid interference. Also, avoid direct heat and sunlight.

We advise you to place the telephone on a table cloth or similar, as the rubber feet on the base can mark some surfaces

Handset Range

The telephone has a range of 30-50 metres indoors and up to 300 metres outdoors. The range will be reduced when there is no clear line of sight between the base and handset. Place the base as high as practically possible to ensure the best signal between the base and the handset. The  icon at the top left of the LCD display will blink and the signal strength bars will disappear to warn you if you have moved out of range of the base. You will need to move closer to the base station as the telephone line might be disconnected and the handset will return to standby.

INSTALLATION

Setting Up

Plug the power cable into the power socket on the base. Plug the adaptor end of the power cable into the mains supply and switch the supply on. (*)

Connect the line cord plug to the line socket on the base. Connect the other end of the line cord to the PTT socket. (**)

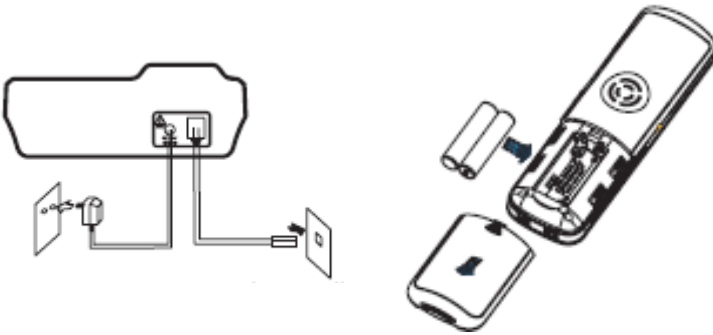

Install the rechargeable batteries in the handset. The handset requires two Nickel Metal Hydride (NiMH) AAA batteries. These are supplied with your telephone. Slide the battery cover in the direction of the arrow and pull it out. Check the battery polarity diagrams on the handset when inserting the batteries. Fit the battery cover by sliding the cover on to the back of the handset until it snaps shut.

(*) Classified "hazardous voltage" according to EN60950 standard

(**) Classified TNV-3 according to EN60950 standard.

INSTALLATION

Place the handset on the base, a short beep will be heard. The battery symbol  will be displayed on the handset. Once the handset is fully charged, the display will show a full battery symbol.

The telephone has an automatic charging control to avoid excessive charging.

Before the handset can be used, the handset batteries must be charged for a minimum of 15 hours on the PhotoDECT base.



Battery Use

The  icon is continuously displayed at the top right corner of the LCD display. The icon indicates the level of battery power. The more bars displayed, the more power available.



When the battery is too weak for the telephone to operate, the handset will automatically switch off. Place the handset on the base to charge the handset battery. Under ideal conditions, the handset battery should give about 6 hours talktime or 150 hours standby on a single charge.

HANDSET SETTINGS

On/Off Settings

When the handset is placed on the charger it automatically switches on. Alternatively, press  for about 5 seconds. The telephone will enter subscription mode in which the handset is searching for a registered base.

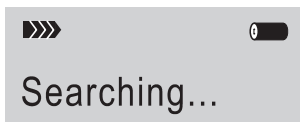

On successfully finding a base, the LCD window will display the time (either set by yourself – see Handset Settings – Set Date & Time or it will be set automatically when you receive a call provided that you subscribe to a Caller ID service) and the handset number. The telephone is now in standby mode and is ready for use.

To turn the handset off, press  for about 5 seconds again. The LCD display will then switch off.

Note: When battery power is very low, the following is displayed. You must recharge immediately i.e. replace the handset on the base.

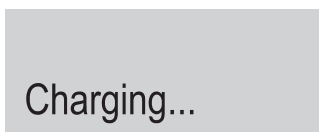

HANDSET SETTINGS

Alarm Setting



You are able to set an alarm and adjust the settings using the handset.  will be displayed if you set the alarm to ring.

Press  (left side) to activate the menu

Use  and  to scroll through the menu to select **'HS SETTING'**



Press  (left side) to confirm



Press  (left side) to select **'ALARM'**

Use  and  to scroll through the menu to select **'ON'** or **'OFF'**

If you select **'ON'** you will be prompted to enter the time in HH:MM format (24 hour format). Enter the alarm time using the numeric keypad.

Press  (left side) to confirm

Use  and  to scroll through the menu to select **'SNOOZE ON'** or **'SNOOZE OFF'**

Press  (left side) to confirm. Either press  to return to standby or wait 30 seconds

Notes:



Press any key to silence the alarm. If you select **'SNOOZE ON'**, the alarm will ring at regular intervals of 11 minutes. Set snooze to off by pressing .

HANDSET SETTINGS



Audio Setup

The hands free speaker volume can be adjusted. Likewise, if using an earpiece, the volume heard through the earpiece can be adjusted.



Press  (**left side**) to activate the menu



Use  and  to scroll through the menu to select '**HS SETTING**'



Press  (**left side**) to confirm

Use  and  to scroll through the menu to select '**AUDIO SETUP**'

Press  (**left side**) to confirm

Use  and  to scroll through the menu to select '**SPEAKER VOL**' or '**EARPIECE VOL**'.

Use  and  to scroll through the menu to select required volume. There are 5 volume settings

Press  (**left side**) to confirm. Either press  to return to standby or wait 30 seconds

HANDSET SETTINGS

Ringer Setup



Ringer Tones

There is a choice of 10 handset ringer tones to notify you of incoming calls. You can select different tones to notify you if the call is internal (from other handsets registered to the same base) or external (from the telephone network).



Press  (left side) to activate the menu

Use  and  to scroll through the menu to select 'HS SETTING'



Press  (left side) to confirm



Use  and  to scroll through the menu to select 'RING SETUP'



Press  (left side) to confirm

Use  and  to scroll through the menu to select 'INT RING/EXT RING'

Press  (left side) to confirm

Use  and  to scroll through the menu to select 'MELODY'

Use  and  to scroll through the menu to select desired ringer tone/melody (1-10). As you scroll through, the telephone demonstrates the selected tone/melody



Press  (left side) to confirm. Either press  to return to standby or wait 30 seconds

HANDSET SETTINGS



Ringer Volume

There is a choice of five handset ringer volumes. The handset ringer can also be turned off.



Press  (**left side**) to activate the menu

Use  and  to scroll through the menu to select
'HS SETTING'

Press  (**left side**) to confirm



Use  and  to scroll through the menu to select
'RING SETUP'



Press  (**left side**) to confirm

Use  and  to scroll through the menu to select
'INT RING/EXT RING'

Press  (**left side**) to confirm

Use  and  to scroll through the menu to select
'VOLUME'

Use  and  to scroll through the menu to select
desired ringer volume (1 to 5 + off position). As you
scroll through, the telephone demonstrates the selected
volume

Press  (**left side**) to confirm. Either press  to
return to standby or wait 30 seconds



HANDSET SETTINGS

Tone Setup



A key tone is heard every time you press a key on the handset. This can be switched to silent.

Note: Warning tones will still be emitted when an incorrect key is pressed.

Press  (**left side**) to activate the menu



Use  and  to scroll through the menu to select 'HS SETTING'



Press  (**left side**) to confirm

Use  and  to scroll through the menu to select 'TONE SETUP'

Press  (**left side**) to confirm

Press  (**left side**) again to select 'KEY TONE'

Use  and  to scroll through the menu to select 'ON' or 'OFF'



Press  (**left side**) to confirm. Either press  to return to standby or wait 30 seconds

HANDSET SETTINGS



Range Alarm

A beep will emit a sound when the handset is out of range from the base. You are able to enable/disable this audible warning.

Press  (**left side**) to activate the menu

Use  and  to scroll through the menu to select '**HS SETTING**'



Press  (**left side**) to confirm



Use  and  to scroll through the menu to select '**TONE SETUP**'

Press  (**left side**) to confirm

Press  to select '**RANGE ALARM**'

Press  (**left side**) to confirm

Use  and  to scroll through the menu to select '**ON**' or '**OFF**'



Press  (**left side**) to confirm. Either press  to return to standby or wait 30 seconds

HANDSET SETTINGS



Language Settings

The handset supports 8 predefined languages: English, French, Spanish, Deutsch, Italiano, Nederlands, Ploski, Chinese. You can select the language used to display menu options.



Press  (**left side**) to activate the menu



Use  and  to scroll through the menu to select
'HS SETTING'

Press  (**left side**) to confirm

Use  and  to scroll through the menu to select
'LANGUAGE'

Press  (**left side**) to confirm

Use  and  to scroll through the menu to select the desired language. Each language will be displayed in its own native translation

Press  (**left side**) to confirm. Either press  to return to standby or wait 30 seconds



HS Label

The handset has a name - "HS n" (where n is either 1,2,3,4 or 5). This number indicates that the handset is the nth handset registered to the base i.e. HS 1 is the 1st handset registered to



HANDSET SETTINGS

the base. The Handset name is displayed in standby mode. If desired, it can be changed.

Press  (**left side**) to activate the menu



Use  and  to scroll through the menu to select
'HS SETTING'

Press  (**left side**) to confirm

Use  and  to scroll through the menu to select
'HS NAME'

Press  (**left side**) to confirm

Enter the new handset name (up to 6 characters) using the numeric keypad (see Phonebook – Add New Entry).
Press  (**right side**) to delete the previous character if incorrect.



Press  (**left side**) to confirm. Either press  to return to standby or wait 30 seconds

Auto Answer



Auto answer allows you to answer a call by simply picking up the handset from the base without pressing any key.

Press  (**left side**) to activate the menu



HANDSET SETTINGS



Use  and  to scroll through the menu to select 'HS SETTING'

Press  (**left side**) to confirm

Use  and  to scroll through the menu to select 'AUTO ANSWER'

Press  (**left side**) to confirm



Use  and  to scroll through the menu to select 'ON' or 'OFF'.

Press  (**left side**) to confirm. Either press  to return to standby or wait 30 seconds

LCD Settings

There are 17 LCD contrast settings available.

Press  (**left side**) to activate the menu



Use  and  to scroll through the menu to select 'HS SETTING'



Press  (**left side**) to confirm

HANDSET SETTINGS

Use  and  to scroll through the menu to select
'CONTRAST'

Press  (**left side**) to confirm

Use  and  to scroll through the 17 available
contrast levels.



Press  (**left side**) to confirm. Either press  to
return to standby or wait 30 seconds

Date and Time Setting



Date Format

The date format displayed on the handset can be changed. The format can be either dd//mm or mm/dd.

Press  (**left side**) to activate the menu

Use  and  to scroll through the menu to select
'HS SETTING'

Press  (**left side**) to confirm



Use  and  to scroll through the menu to select
'DATE & TIME'



Press  (**left side**) to confirm

HANDSET SETTINGS

Press  (**left side**) again to select
'DATE FORMAT'

Press  (**left side**) to confirm.



Use  and  to scroll through the menu to select
'DD-MM' or 'MM-DD'

Press  (**left side**) to confirm. Either press  to
return to standby or wait 30 seconds

Time Format

The time format displayed on the handset can be changed. The format can be either 12 hour or 24 hour.

Press  (**left side**) to activate the menu

Use  and  to scroll through the menu to select
'HS SETTING'

Press  (**left side**) to confirm

Use  and  to scroll through the menu to select
'DATE & TIME'



Press  (**left side**) to confirm



Press  (**left side**) again to select

HANDSET SETTINGS

'TIME FORMAT'



Press  (left side) to confirm.

Use  and  to scroll through the menu to select
'12-Hour' or '24-Hour'



Press  (left side) to confirm. Either press  to
return to standby or wait 30 seconds

Date & Time Setting



Press  (left side) to activate the menu

Use  and  to scroll through the menu to select
'HS SETTING'

Press  (left side) to confirm

Use  and  to scroll through the menu to select
'DATE & TIME'



Press  (left side) to confirm

Use  and  to scroll through the menu to select
'SET DATE' or 'SET TIME'

Press  (left side) to confirm.

HANDSET SETTINGS

Enter the current date or time (24hr format) using the numeric keypad



Press  (**left side**) to confirm. Either press  to return to standby or wait 30 seconds

Notes: If you subscribe to a Caller ID service, the time will be set automatically when you receive a call.



Select Base

You can select a base from those already registered to the handset



Press  (**left side**) to activate the menu

Use  and  to scroll through the menu to select '**HS SETTING**'

Press  (**left side**) to confirm

Use  and  to scroll through the menu to select '**SELECT BS**'

Press  (**left side**) to confirm

Use  and  to scroll through the list of registered bases to select the base required

Press  (**left side**) to confirm



HANDSET SETTINGS

'SELECT BS n' will be displayed (n is the number of the registered base). Press  (**left side**) to confirm, a confirmation beep will be heard



Handset Default

You can reset the handset settings to the factory default.

Press  (**left side**) to activate the menu

Use  and  to scroll through the menu to select 'HS SETTING'

Press  (**left side**) to confirm

Use  and  to scroll through the menu to select 'HS RESET'

Press  (**left side**) to confirm

You will be prompted to enter the PIN code (default is 0000).

Press  (**left side**) to confirm



If the PIN code is accepted, all handset settings will be reset to the factory default. You will automatically be returned to standby mode

BASE SETTINGS

Terminate Handset

You can delete a handset registration from a base.

Press  (**left side**) to activate the menu



Use  and  to scroll through the menu to select
'**BS SETTING**'

Press  (**left side**) to confirm

Press  (**left side**) again to select
'**TERMINATE HS**'

You will be prompted to enter the PIN code (default is
0000).

Press  (**left side**) to confirm

Use  and  to scroll through the list of registered
handsets to select the handset required

Press  (**left side**) to confirm (if the current handset
or a non existant handset is selected, a warning beep will
be heard)

The selected handset will be deregistered



BASE SETTINGS

Dial Mode Setting



In the UK, all telephone exchanges now use Tone dialling. The dial mode setting is pre-set to Tone.

If your telephone does not dial out, it is probably being used from an older private switchboard (PBX). In this case, the dial mode must be changed to Pulse.



Press  (**left side**) to activate the menu



Use  and  to scroll through the menu to select '**BS SETTING**'

Press  (**left side**) to confirm

Use  and  to scroll through the menu to select '**DIAL MODE**'

Press  (**left side**) to confirm











Use  and  to scroll through the menu to select '**TONE**' or '**PULSE**'.

Press  (**left side**) to confirm. Either press  to return to standby or wait 30 seconds

BASE SETTINGS

Flash Time Setting

The flash time setting can be changed.

Press  (left side) to activate the menu
Use  and  to scroll through the menu to select ' BS SETTING '
Press  (left side) to confirm
Use  and  to scroll through the menu to select ' FLASH TIME '
Press  (left side) to confirm
Use  and  to scroll through the menu to select ' Flash 1 ' or ' Flash 2 '.
Press  (left side) to confirm. Either press  to return to standby or wait 30 seconds

Flash 1= 100ms



Flash 2= 300ms

BASE SETTINGS



Modify PIN

The PIN is pre-set to '0000'. This can be changed – this is recommended for confidentiality.

Press  (**left side**) to activate the menu

Use  and  to scroll through the menu to select 'BS SETTING'

Press  (**left side**) to confirm



Use  and  to scroll through the menu to select 'MODIFY PIN'

Press  (**left side**) to confirm

You will be prompted to enter the old PIN code (default is 0000). If the old PIN code is accepted, you will be prompted to enter a new PIN code.

Enter new PIN code and press  (**left side**) to confirm.

You will be prompted to confirm the new PIN code.
Enter new PIN code again..

Press  (**left side**) to confirm. Either press  to return to standby or wait 30 seconds

BASE SETTINGS

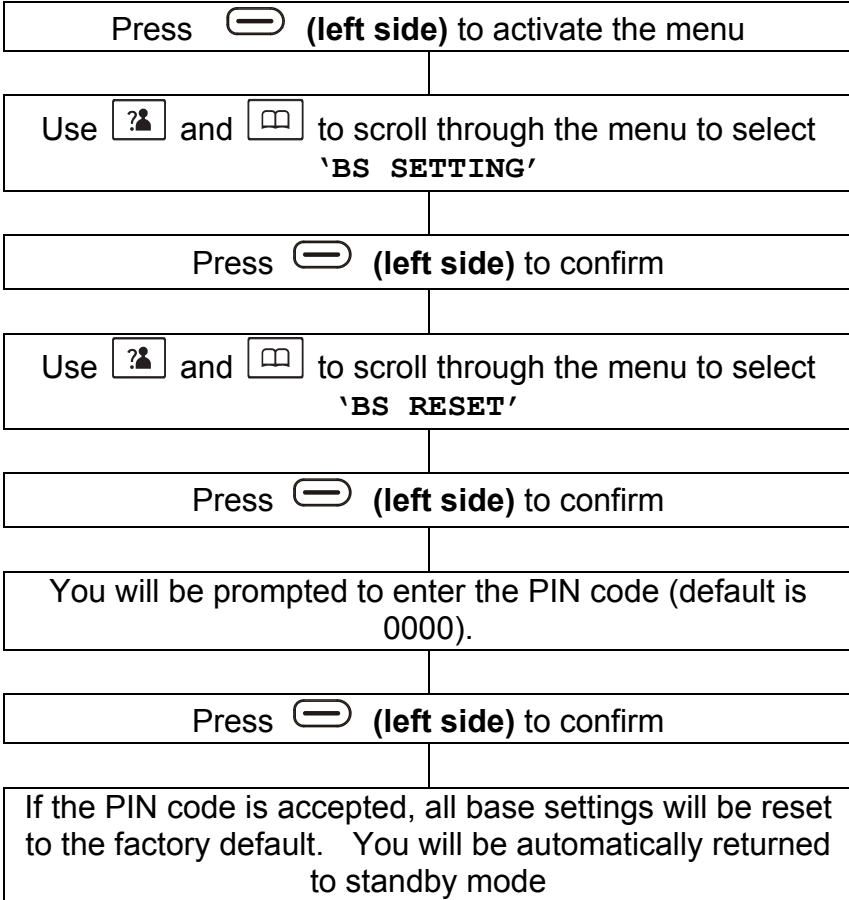

Base Default

You can reset the base settings to the factory default.



USING THE TELEPHONE

Making a Call

Pick up handset.
Press .  will be displayed on the LCD

When you hear dialing tone, dial the number on the keypad.

To end the call simply press  or place the handset on the base



Pre-Dialling

Pick up handset. Dial the number on the keypad (up to 32 digits)

Press , the number is automatically dialled

To end the call simply press  again or place the handset on the base

Note: If you make an incorrect entry while pre-dialling the telephone number :

- Press  (**right side**) to clear the last digit and then enter the correct number
- Press  (**right side**) for more than one second to clear all digits entered and return to standby mode.

USING THE TELEPHONE

Receiving a Call

When an incoming call is received the telephone rings. If the caller can be identified (due to subscription to a Caller ID service), the caller's telephone number will be displayed. If this caller's number is stored on the Phonebook, the associated name will be displayed.



Press  to answer

Or

If auto answer is activated, simply lift the handset out of the base

To end the call simply press  or replace the handset on the base

Call duration is always displayed once you hang up.



Note: You can alter the ringer volume whilst the telephone is ringing. Simply use  and  to select the desired volume.



Hands Free

You can turn on the speakerphone built into the handset either before or during a call. In this mode there is no need to hold the handset. You will hear the third party through the speaker and the microphone will pick up your voice.

Before making a call, press  twice to turn hands free on.

The  icon will be displayed on the LCD.

Press  during a call to turn hands free on. The  icon will be displayed on the LCD.

Press  again during a call to turn hands free off. The  icon will disappear from the LCD.

Note: To adjust the speakerphone volume use Audio Setup in Handset Settings.

USING THE TELEPHONE

Mute Function

If you wish, you can speak privately to someone else in the room with you without your caller overhearing.



You will still be able to hear the caller but they cannot hear you during the mute operation.

During a call, press  (right side)

The LCD will show 'CALL MUTED' which indicates that your voice is muted to the call and the caller cannot hear you speaking

Press  (right side) again to resume the conversation. 'CALL MUTED' will disappear from the LCD display

Receiving Volume

During a conversation, the  and  keys adjust the ear piece volume level. The volume can be adjusted from level 1 to 5. The selected volume is displayed in the LCD display. The receiving volume range is 0dB to 12dB.

USING THE TELEPHONE

Last Number Redial

To redial the last number dialled:



Pick up handset.
Press  in standby mode

Press  to dial the number

Recalling Recent Numbers

You can call back any of the last 10 numbers dialled as follows:

Pick up handset.
Press  in standby mode

Use  and  to scroll through the dialled numbers until you find the number you wish to call

Press  to dial the number

Notes:



- When no numbers are found, **EMPTY** is displayed
- If the redial memory is full i.e. 10 numbers stored, each time you dial a new number, the oldest number stored is automatically erased and the redial memory is updated.

USING THE TELEPHONE

Adding Recent Numbers to the Phone Book

Pick up handset.

Press  in standby mode

Use  and  to scroll through the dialled numbers until you find the number you wish to add to phone book

Press  (**left side**) to confirm



Press  (**left side**) again to select 'ADD TO PB'

The display will show 'NAME?' Enter the name you wish using the numeric keypad (see character map below)



Press  (**left side**) to confirm

The display will show the selected number from the recently dialled list

Press  (**left side**) to confirm

Use  and  to scroll through the melody menu to select desired ringer tone. As you scroll through, the telephone demonstrates the selected melody. If you want to set a VIP number, you should select a special ring tone. The ring tone should be different from the external ring you have set. You can set up to 9 VIP ring tones associated with 9 numbers

USING THE TELEPHONE

Press  (**left side**) to confirm. Press  to return to standby or wait 30 seconds

USING THE TELEPHONE

Deleting Recent Numbers



To delete a specific number in the redial memory

Pick up handset.

Press  in standby mode

Use  and  to scroll through the dialled numbers until you find the number you wish to delete

Press  (**left side**) to select

Use  and  to scroll through the menu to select **'DELETE'**

Press  (**left side**) to confirm

You will be prompted to confirm, press  (**left side**) again to confirm



USING THE TELEPHONE

To delete all numbers in the redial memory

Pick up handset.

Press  in standby mode

Press  (**left side**) to select

Use  and  to scroll through the menu to select
'DELETE ALL'

Press  (**left side**) to select

You will be prompted to confirm, press  (**left side**)
again to confirm

USING THE TELEPHONE

Flash Signal

The  (left side) key can also be used with special services such as Call Waiting (if provided by your service provider) or transferring external calls to another extension within a private switchboard. The LCD will display 'R'.

Paging the Handset

If you wish to locate the handset simply follow the instructions below:

Press , located on the bottom of the base for less than 2 seconds



All registered handsets will be paged and will ring for about 60 seconds



Press any button on the located handset or press  on the base again to stop paging mode



Call Timer

Your handset automatically times the duration of every external call. The time is shown during the call and for a few seconds after the call has ended.

Key Lock

When this feature is turned on, all buttons except for  will be locked and will not function. You can use  for answering incoming or intercom calls. When you complete the call and hang up, the telephone returns to lock mode. This lock feature is useful to avoid pressing buttons by mistake.

Switch lock On: Press  until the  icon and 'HS LOCKED' appear in the LCD display

Switch lock Off: Press  until the  icon disappears in the LCD display

CALLER ID



The features described in this section are only available if you subscribe to a Caller ID service from your network provider.

Caller ID means you can see who is calling on your handset display (provided the number is not withheld, unavailable or is an international call).

The display shows '**PRIVATE**' for a withheld number.

The display shows '**OUT OF AREA**' when someone calls from an area where the telephone company is not offering caller identification services or is not yet providing number delivery to your area.

Whether you take a call or not, the caller's details are stored in the Caller ID book. This book stores the last 40 incoming calls.

The  icon will be shown on the LCD if you missed one or more calls. If the Caller ID book is full, the  icon will blink.



CALLER ID

View Caller ID Book

Press  (left side) to activate the menu

Press  (left side) to select
'CID BOOK'

The list of numbers in the Caller ID book will be displayed

Use  and  to scroll through the list



Alternatively, you can access the book by pressing  key whilst in standby mode.

Note: If there are no caller ID telephone numbers in the call book, 'EMPTY' is displayed

Dial a Number from the Caller ID Book

Pick up handset.
Press  in standby mode

The list of numbers in the Caller ID book will be displayed

Use  and  to scroll through the list to find the required number

Press , the number is automatically dialled



CALLER ID

Add a Number from the Caller ID Book to the Phone Book

Pick up handset and press **MENU**

Press  (**left side**) to chose MORE in standby mode

The list of numbers in the Caller ID book will be displayed

Use  and  to scroll through the list until you find the required number



Press  (**left side**) again to select 'ADD TO PB'



The display will show 'NAME?' Enter the name you wish using the numeric keypad (see character map below)

Press  (**left side**) to confirm

The display will show the selected number from the CID book

Press  (**left side**) to confirm



Use  and  to scroll through the melody menu to select desired ringer tone. As you scroll through, the telephone demonstrates the selected melody. If you want to set a VIP number, you should select a special ring tone. The ring tone should be different from the external ring you have set. You can set up to 9 VIP ring tones associated with 9 numbers

Press  (**left side**) to confirm. Press  to return to standby or wait 30 seconds

CALLER ID

Delete a Number from the Caller ID Book

Pick up handset and Press **MENU**
Press  (**left side**) to chose More in standby mode

Use  and  to scroll through the list until you find the number you wish to delete

Press  (**left side**) to select

Use  and  to scroll through the menu to select '**DELETE**'

Press  (**left side**) to confirm

You will be prompted to confirm, press  (**left side**) again to confirm

Delete All Numbers from the Caller ID Book

Pick up handset.
Press  in standby mode

Press  (**left side**) to select

Use  and  to scroll through the menu to select '**DELETE ALL**'

Press  (**left side**) to select



You will be prompted to confirm, press  (**left side**) again to confirm

PHONE BOOK

Telephone numbers can be stored in the phone book. It allows you to store frequently used numbers so that you can easily make a call without having to remember or enter the telephone number. The phone book can contain 50 entries. Each phone number can contain up to 20 digits and have a name of up to 12 characters.

Create a Phone Book Entry

Press  (**left side**) to activate the menu

Use  and  to scroll through the menu to select '**PHONE BOOK**'



Press  (**left side**) to select

Press  (**left side**) again to select '**NEW**'



The display will show '**NAME?**' Enter the name you wish using the numeric keypad (see character map below).
Up to 12 characters

Press  (**left side**) to confirm

The display will show '**NUMBER?**' Enter the telephone number you wish using the numeric keypad (up to 20 digits)

Use  and  to scroll through the melody menu to select desired ringer tone. As you scroll through, the telephone demonstrates the selected melody. If you want to set a VIP number, you should select a special ring tone for it. The ring tone should be different from the external ring you have set. You can set up to 9 VIP ring tones associated with 9 numbers

PHONE BOOK

Press  (**left side**) to confirm. You can then repeat the process again and add another entry to the phonebook or press  to return to standby or wait 30 seconds

Note: Press  (**right side**) to clear the last digit and then enter the correct number

Press  (**right side**) for more than one second to clear all digits entered and return to standby mode.

Insert Pause

Inserting a pause provides a delay of 3 seconds. This is necessary with some telephone systems.

To insert a dialling pause between numbers when storing a number, press  until P appears in the LCD display.

Character Map

Key	Characters in order				
0	(space)	0	&	/	.
1	-	1	@		
2	A	B	C	2	
3	D	E	F	3	
4	G	H	I	4	
5	J	K	L	5	
6	M	N	O	6	
7	P	Q	R	S	7
8	T	U	V	8	
9	W	X	Y	Z	9



PHONE BOOK

View Phone Book Entries

Pick up handset.

Press  in standby mode

The list of names in the phone book will be displayed

Use  and  to scroll through the list to find the required name



Press  (**left side**) to view the telephone number

Dialling using a Phone Book Entry

Pick up handset.

Press  in standby mode

The list of names in the phone book will be displayed



Use  and  to scroll through the list to find the required name

Press  , the number is automatically dialled



PHONE BOOK

Modify a Phone Book Entry



Press  (**left side**) to activate the menu

Use  and  to scroll through the menu to select
'PHONE BOOK'

Press  (**left side**) to select

Use  and  to scroll through the menu to select
'EDIT'

Press  (**left side**) to select

Use  and  to scroll through the list to find the
required phone book entry to be modified

Press  (**left side**) to confirm



The cursor will start to flash on the right hand side of the
name. Modify name using  (**right side**) to clear the
previous digits and then enter the correct character(s)



Press  (**left side**) to confirm

The cursor will start to flash on the right hand side of the
number. Modify name using  (**right side**) to clear
the previous digits and then enter the correct character(s)

PHONE BOOK



Press  (left side) to confirm

Use  and  to scroll through the melody menu to select desired ringer tone. As you scroll through, the telephone demonstrates the selected melody. If you want to set a VIP number, you should select a special ring tone for it. The ring tone should be different from the external ring you have set. You can set up to 9 VIP ring tones associated with 9 numbers



Press  (left side) to confirm. You can then repeat the process again and modify another entry in the phonebook or press  to return to standby or wait 30 seconds

Delete a Phone Book Entry



Press  (left side) to activate the menu

Use  and  to scroll through the menu to select 'PHONE BOOK'

Press  (left side) to select

Use  and  to scroll through the menu to select 'DELETE'

Press  (left side) to select

Use  and  to scroll through the list to find the required phone book entry to be deleted



PHONE BOOK

Press  (left side) to select



You will be prompted to confirm, press  (left side) again to confirm

Delete All Phone Book Entries

Press  (left side) to activate the menu

Use  and  to scroll through the menu to select 'PHONE BOOK'

Press  (left side) to select

Use  and  to scroll through the menu to select 'DELETE ALL'

Press  (left side) to select



You will be prompted to confirm, press  (left side) again to confirm

PHONE BOOK



Phone book Status

The phone book status shows the number of entries already stored in the phone book e.g. 05/50

Press  (left side) to activate the menu

Use  and  to scroll through the menu to select 'PHONE BOOK'

Press  (left side) to select

Use  and  to scroll through the menu to select 'PB STATUS'

Press  (left side) to select

The number of entries already stored in the phone book will be displayed

Press  to return to standby or wait 30 seconds

PHOTO DIAL

Storing a Number to Photo Dial Memory

There are 10 photo dial memory buttons. You can slip your contact's photograph under the perspex of the button. This is very useful if you tend to forget telephone numbers or names.

Press **MEMO** (found on the base) whilst the telephone is on-hook

_ - - - - - _ is displayed. Enter the telephone number to be stored (up to 32 digits) using the **numeric keypad found on the base (M0-M9)**.

Press **MEMO** followed by one of the photo dial buttons **found on the base (M0-M9)**.

_ - - - - - _ is displayed to confirm

Dialling a Photo Dial Number

Press the  button to obtain a dialling tone.

Press one of the photo dial buttons M1, M2, ... M10 and the number will be automatically dialed.

Delete and Replace A Photo Dial Number

Follow the instructions in the 'Storing a Number to Memory' section.

Entering a new number into a photo dial location which currently stores a telephone number will automatically erase the original number.

Delete all Photo Dial Numbers

Whilst in the on-hook position press and hold the **MEMO** button found on the telephone base. This action will delete all the numbers stored in the photo dial memory buttons.

ADDITIONAL HANDSETS & BASES

The handset that came with your base is already registered to the base (factory setting). This is registered as handset 1. Each additional handset you purchase must be registered to the base.

Up to 5 handsets can be registered to one base unit. This means you can make internal calls between registered handsets, transfer an incoming call between handsets and answer a call anywhere in the office/home at any time as all the handsets will call at the same time.



You can also register up to 4 base units to each handset. This will increase the phone range, allowing you to move between the telephone coverage areas.

ADDITIONAL HANDSETS & BASES



Register a new Handset

Before registering a handset to the base, you should press and hold the  key on the bottom of the base for about 5 seconds and then release it.

Press  (**left side**) to activate the menu

Use  and  to scroll through the menu to select 'REGISTRATION'

Press  (**left side**) to select

Use  and  to scroll through the base names list

Press  (**left side**) to select desired base. The handset will search for the requested base and the relevant information will flash on the LCD.

If the base is found and the handset is successfully registered, you will be prompted to enter the PIN code (the default is 0000).

If the PIN code is accepted, the registration tone will sound and the base assigns a number to the handset. If the PIN code entered is invalid, a warning tone will sound, and the handset will return to the previous registration state.

ADDITIONAL HANDSETS & BASES

Select a Base

Your handset can be used with up to 4 bases. See Select Base in Handset Settings.

Note: In order to use the handset with more than one base unit, the handset must be registered with each base (see Register a New Handset section).

Release a Handset

A registered handset can be removed from a base if necessary. See Terminate Handset in Base Settings.

ADDITIONAL HANDSETS & BASES

Internal Calls

When using several handsets registered to the same base unit, you can make internal calls and transfer external calls between handsets.

Make an Internal Call

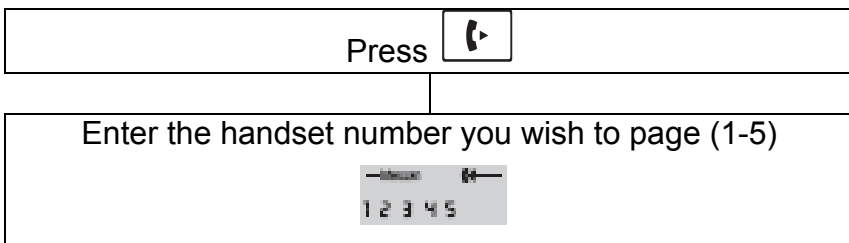



Notes:

If an incorrect handset number is entered i.e. one that does not exist, the handset will sound an error tone

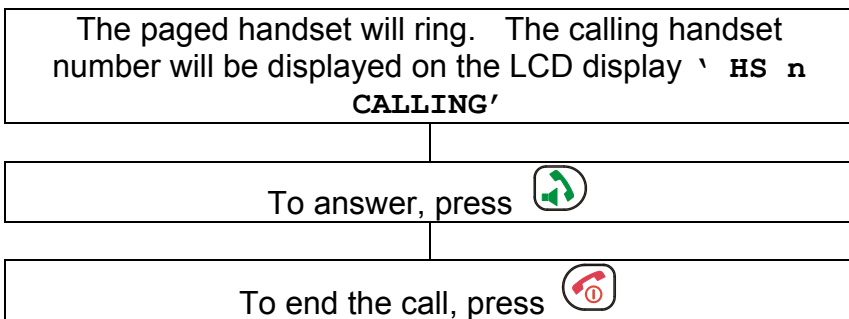
Receive an Internal Call



Notes:

If there is an external call during the course of an internal call, the caller's telephone number will be displayed. The internal call can be finished by pressing . The normal external call ring tone will be heard, press  to answer the call.

ADDITIONAL HANDSETS & BASES

Call Transfer between Handsets

An external call can be transferred from one handset to another.

During an external call, when you wish to transfer the call, press . Your external caller will be placed on hold

Enter the handset number you wish to transfer to (1-5)

The paged handset will ring. The calling handset number will be displayed on the LCD display 'HS n CALLING'

To answer the paged handset, press 

If required, you may now speak to the paged user.

To transfer the external call to the paged handset, press



O R

To cancel the call transfer and talk to the external caller again, press 

Notes:

On transferring a call, you may hang up before the paged handset answers. The connection between the external caller and the paged handset is complete once you hang up.

If the paged handset does not answer a call within a predetermined time, the call will be transferred back to your handset.

ADDITIONAL HANDSETS & BASES

Three Way Conference Call

When you have both an external call and an intercom call in progress, you can set up a three way conference call

During an external call, press . Your external caller will be placed on hold

Enter the handset number you wish to join the three way conference call (1-5)

The paged handset will ring. The calling handset number will be displayed on the LCD display 'HS n CALLING'

To answer the paged handset, press 

The caller can now press  to start the three way call

Either of the two internal handsets can press  to leave the conference call at any time.

CALL WAITING

Caller ID on Call Waiting

When you subscribe to a Call Waiting service from your local telephone service provider, the LCD will display the name and number of the second caller while you are having a conversation with the first caller.

Press  (**left side**) + the number 2 to answer the second caller

When you have finished with the second caller press  (**left side**) again + the number 2 to resume your conversation with the first caller.

Note: If you have transferred an external call to another handset, the call waiting function will not work via the second handset.

TROUBLESHOOTING

General Checks

- Make sure that the telephone line cord and adaptor are correctly plugged in and they are not damaged.
- Make sure the batteries are inserted correctly.
- Make sure that the batteries are fully charged.
- Connect another telephone to the telephone PTT socket or move your telephone to another socket to track if the failure is coming from your telephone or your PTT socket.
- Make sure the power adaptor is properly connected

Handset not registering

- See general checks.

No display

- See general checks
- Check the handset is switched on

No connection between handset and base

- You may be out of range of the base. Move closer to the base

Handset on the base does not charge

- Make sure the handset is placed properly on the base. When charging, the battery symbol should be shown filling up.

Handset does not ring

- See general checks
- Ensure the ringer volume is not switched off

No tone when you press

- See general checks.
- Check for the handset number on the LCD display e.g. HS1. If this is not present you must register the handset (see Handset Registration section)

TROUBLESHOOTING

A warning tone is heard during a call:

- The batteries are empty. The handset needs to be replaced in the base in order to recharge.
- You are out of the base coverage area.

No number is displayed when the telephone rings:

- Please contact your telephone network provider to get the caller ID service.
- Even if you have subscribed to a caller ID service, if the caller does not want to show their number (private number), the display will show '**PRIVATE**'. '**OUT OF AREA**' might also be displayed if it is an international call
- It could be a call from a PBX. Caller ID may not work properly if the telephone is connected to a PBX.

Consistently short battery life

- Clean the charge contacts
- Replace the batteries

Nothing happens when you press any button

- Check the the keylock is switched off

SAFETY INFORMATION

General

Only use the power supply included with the product.

Only use the approved rechargeable batteries supplied.

Do not open the handset (except to replace the handset batteries) or base. Contact the helpline for all repairs.

Never dispose of batteries in a fire. There is a serious risk of explosion and/ or the release of toxic chemicals.

Do not place objects on the line cord or power cable that may cause damage.

If you are sure you are not going to use the telephone for over a month, remove the batteries.

Cleaning

Unplug the telephone. Clean the telephone with a soft cloth.

Keep the base and handset charging contacts clean. Never use polishes or cleaning agents - they could damage the finish or the electrics inside.

Environmental

Do not expose to direct sunlight.

Always ensure there is a free flow of air over the surfaces of the telephone.

Do not place any part of your product in water and do not use it in damp or humid conditions e.g. bathrooms.

Do not expose your product to fire or other hazardous conditions.

Unplug your phone from the telephone socket during thunderstorms because it could damage your telephone. Your guarantee does not cover thunderstorm damage.

The telephone is designed for working within a temperature range of 5°C to 45°C.

GUARANTEE

From the moment your Geemarc product is purchased, Geemarc guarantee it for the period of two years. During this time, all repairs or replacements (at our discretion) are free of charge. Should you experience a problem then contact our help line or visit our website at www.geemarc.com. The guarantee does not cover accidents, negligence or breakages to any parts. The product must not be tampered with or taken apart by anyone who is not an authorized Geemarc representative. The Geemarc guarantee in no way limits your legal rights.

IMPORTANT: YOUR RECEIPT IS PART OF YOUR GUARANTEE AND MUST BE RETAINED AND PRODUCED IN THE EVENT OF A WARRANTY CLAIM.

Please note: The guarantee applies to
the United Kingdom only

DECLARATION: Geemarc Telecom SA hereby declares that this product is in compliance with the essential requirements and other relevant provisions of the Radio and Telecommunications Terminal Equipment Directive 1999/5/EEC and in particular article 3 section 1a, 1b and section 2. The telephone does not operate if the line current is lower than 18 mA.

The declaration of conformity may be consulted at www.geemarc.com



GUARANTEE

Electrical connection: The apparatus is designed to operate from a 230V 50Hz supply only. (Classified as 'hazardous voltage' according to EN60950 standard). The apparatus does not incorporate an integral power on/off switch. To disconnect the power, either switch off supply at the mains power socket or unplug the AC adaptor. When installing the apparatus, ensure that the mains power socket is readily accessible.

Telephone connection: Voltages present on the telecommunication network are classified TNV-3 (Telecommunication Network Voltage) according to the EN60950 standard.

RECYCLING DIRECTIVES

The WEEE (Waste Electrical and Electronic Equipment) has been put in place for the products at the end of their useful life are recycled in the best way.

When this product is finished with, please do not put it in your domestic waste bin.

Please use one of the following disposal options:

- Remove the batteries and deposit them in an appropriate WEEE skip. Deposit the product in an appropriate WEEE skip.
- Or, hand the old product to the retailer. If you purchase a new one, they should accept it.

Thus if you respect these instructions you ensure human health and environmental protection.



For product support and help visit our website at

www.geemarc.com

Telephone 01707 384438

Or fax 01707 832529



UGPhotoDECT_En_Ver 1.8

geemarc UNITED KINGDOM

5 Swallow Court
Swallowfields
Welwyn Garden City
Hertfordshire, AL7 1SB
For product support.
01707 384438

www.geemarc.com

geemarc FRANCE

Parc de l'Etoile
2, rue Galilée 59791
GRANDE SYNTHÉ CEDEX
TEL. SERVICE APRES VENTE.
03 28 58 75 99

www.geemarc.com